

**THE BROASTER COMPANY**

# Cold Top Refrigerator

An American Tradition Since 1954!



- This is the ideal unit to have right beside your Broaster Company pressure fryer for easier loading of your ready to cook Genuine Broaster Chicken®. Simply take the chicken from the refrigerated area and place it in your pressure fryer.
- It's refrigeration at its best, designed for convenience and ease of use in your Broaster kitchen.
- Refrigerated top area is designed to hold a 12" x 20" pan of coated chicken, ready for cooking.
- Inside has available storage for up to three additional pans of coated chicken.
- One 27-1/2" x 11-3/4" plastic cutting board is mounted on the top front edge for a more practical use of your kitchen area.



## The Broaster Company

2855 Cranston Road, Beloit, WI 53511

(800) 365-8278 • (608) 365-0193

Fax (608) 363-7957 • [www.broaster.com](http://www.broaster.com)



# Cold Top Refrigerator

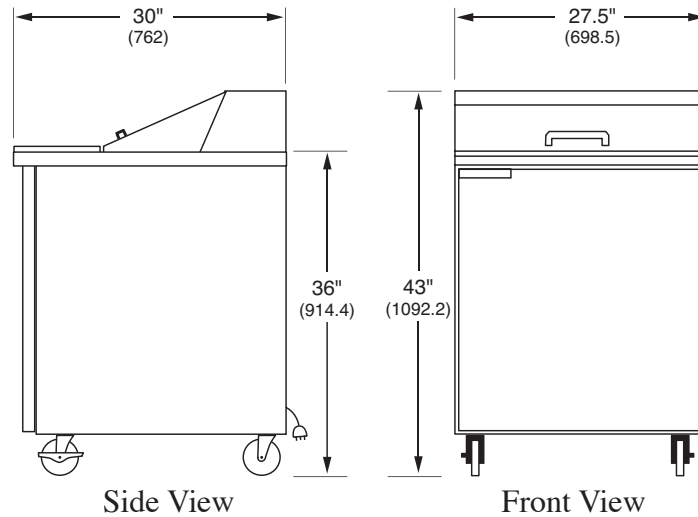

Inches  
(Millimeters)

## SPECIFICATIONS

OVERALL DIMENSIONS			OVERALL HEIGHT	SHIPPING WEIGHT	CUBES	ELECTRICAL
W	D	H				
27.5" (698.5)	30" (762)	36" (914.4)	43" (1092.2)	176 lbs.	25.16	115 volt, single phase, 60 Hz, 4.0 amps, 7' long electrical cord

- Forced-air refrigeration, purposely directed maximum airflow under pans for colder pan temperatures, plus uniform air circulation throughout the cabinet
- Compact 6.5 cu. ft. refrigeration
- Door is hinged on the right
- Special rack inside refrigerator stores three additional 12" x 20" pans
- Pan rack is easily removed for cleaning
- Interior has white aluminum ceiling and sides, covered corners for easy cleaning and a stainless steel floor
- Has four swivel wheels, with the front two locking, for easier movability

### The Broaster Company

2855 Cranston Road, Beloit, WI 53511  
(800) 365-8278 • (608) 365-0193  
Fax (608) 363-7957 • [www.broaster.com](http://www.broaster.com)

