



Smokaroma® Pressure Smoker

Standard Features

- *Fast and productive* – cooking up to 18 racks of fresh bone-in ribs per load in as little as 1 hour*.
- *Safe* – Normal operating pressure is 12 psi. Exhaust will occur between 14 to 15 psi and pressure release valve will release pressure if it exceeds 16 to 17 psi.
- *Cost effective* – Pressure smoking reduces shrinkage up to 40% over other methods.
- *Labor efficient* – Fast and easy operation increases productivity. No watching, basting or turning required. Auto shut-off after cook cycle is complete.
- *Compact* – Requires minimum space in kitchen and casters are standard, making unit portable.
- *Versatile* – Smokes all types of meats, poultry, vegetables, cheese and seafoods.
- *Dual Usage* – Ability to hot smoke or “cold” smoke food products. In hot smoke mode, the main elements will provide heat along with the charring element. In “cold” smoke mode, only the charring element will heat.
- *Customizable* – Any type of wood chips can be used; mesquite, hickory, pecan, cherry, etc. and only 2 ounces are used per cook cycle.
- *No Hood Required* – Approved by UL for ventless applications in both the US and Canada in accordance with the KNLZ commercial cooking appliances with integral systems for limiting the emission of grease-laden air when use in combination with the water bath assembly.



* Cooktime varies with weight of product.

Specifications

The Smokaroma Pressure Smoker combines the modern scientific method of pressure cooking with pressure smoking to create deliciously juicy, smoked foods.

Traditional pits require constant attention, such as turning the food and basting, while the Smokaroma Pressure Smoker eliminates the need for constant labor, while producing flavorful results in much shorter time.

Hot or “cold” smoke food products, including all types of meats, poultry, vegetables, cheese and sea foods.

Compared to the traditional dry method of smoking, pressure smoking locks in the juices and can reduce product shrinkage by 40%, resulting in a moist and flavorful product.

This compact, electric smoker occupies a small footprint and its casters provide additional mobility. With the optional water baffle, a vent hood is not needed to operate, as the unit is completely self-contained.**

The unit is also economical; once the proper pressure is reached, the unit idles and the product smokes on its own.

** Local codes prevail for hood requirements

Smokaroma[®] Pressure Smoker

BC71-BC73

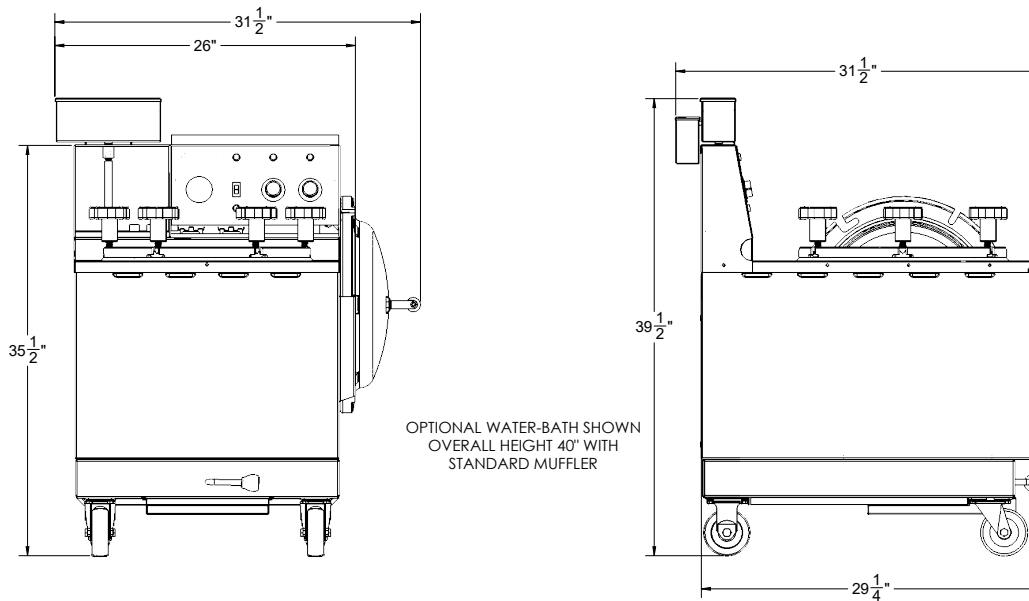

Specifications

| Model | W x D x H (mm) | Capacity | Volts | Hz | Watts | Phase | Weight lbs. (kg) |
|-------|---|--|---------|-------|-------|---------|------------------|
| BC71 | 31.5" x 31.5" x 35.5" (800 mm x 800 mm x 902 mm) 39.5" Height with Water Baffle | Up to 18 racks of Ribs/load Or Up to 12 heads of 8 piece cut Chickens/load | 208/240 | 50/60 | 5,140 | 1 Phase | 200 lbs. (91 kg) |
| BC73 | 31.5" x 31.5" x 35.5" (800 mm x 800 mm x 902 mm) 39.5" Height with Water Baffle | Or Up to 32 lb. Beef/load | 208/240 | 50/60 | 5,140 | 3 Phase | 200 lbs. (91 kg) |

Specifications subject to change without notice.



Shelf/Rack Assembly



Spit/Rib Assembly